

VIEW 5
SCALE 1/2

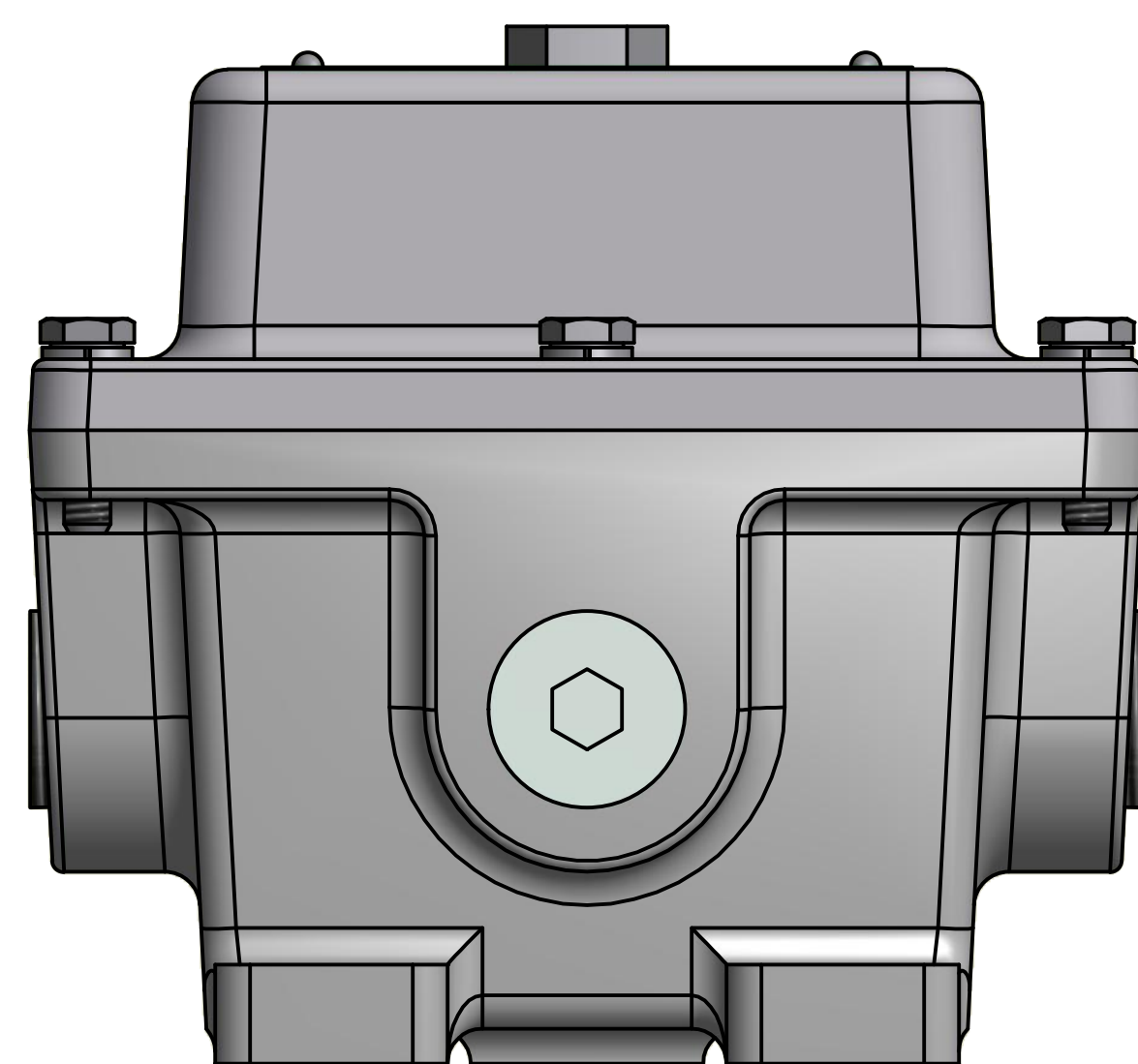
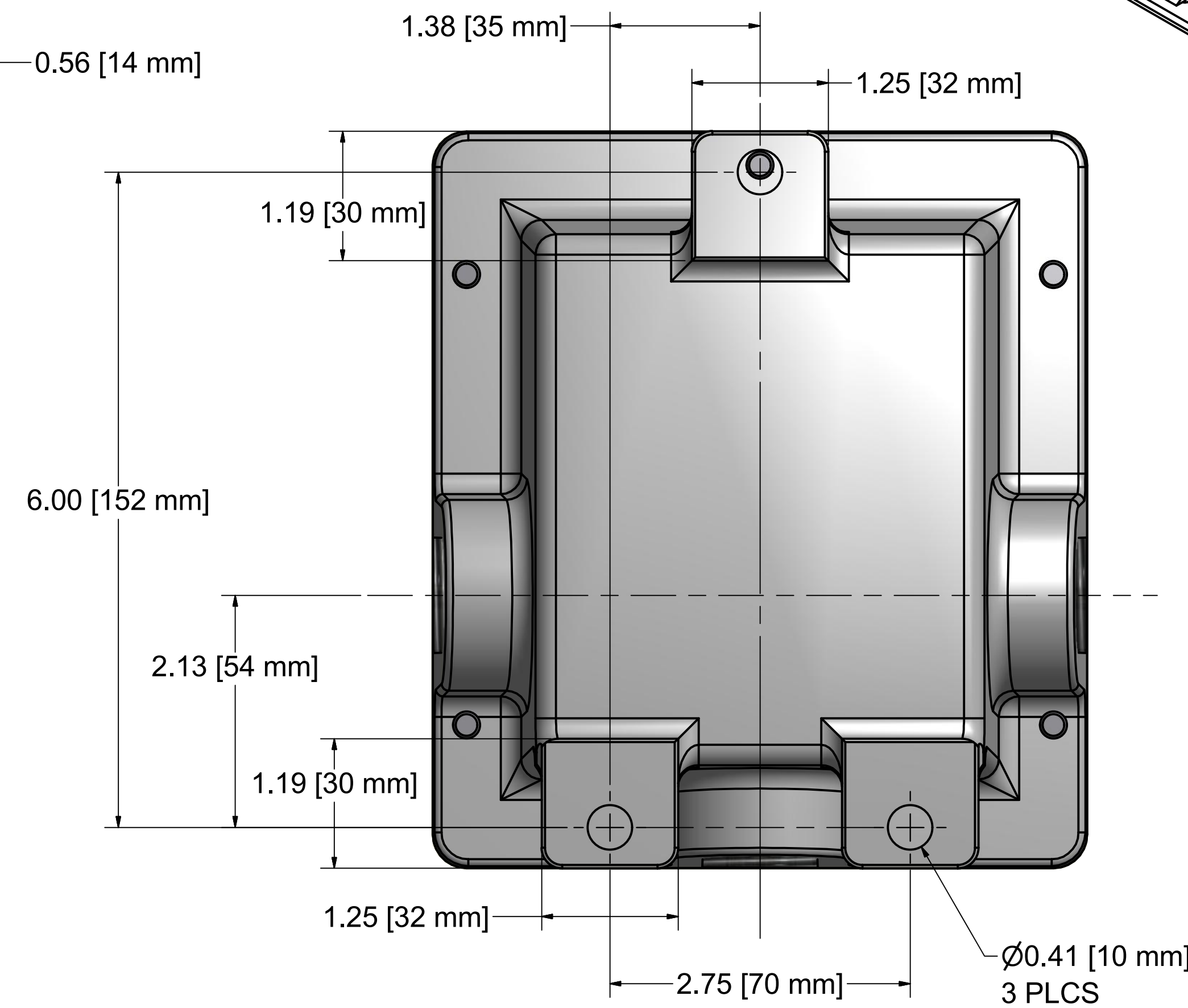
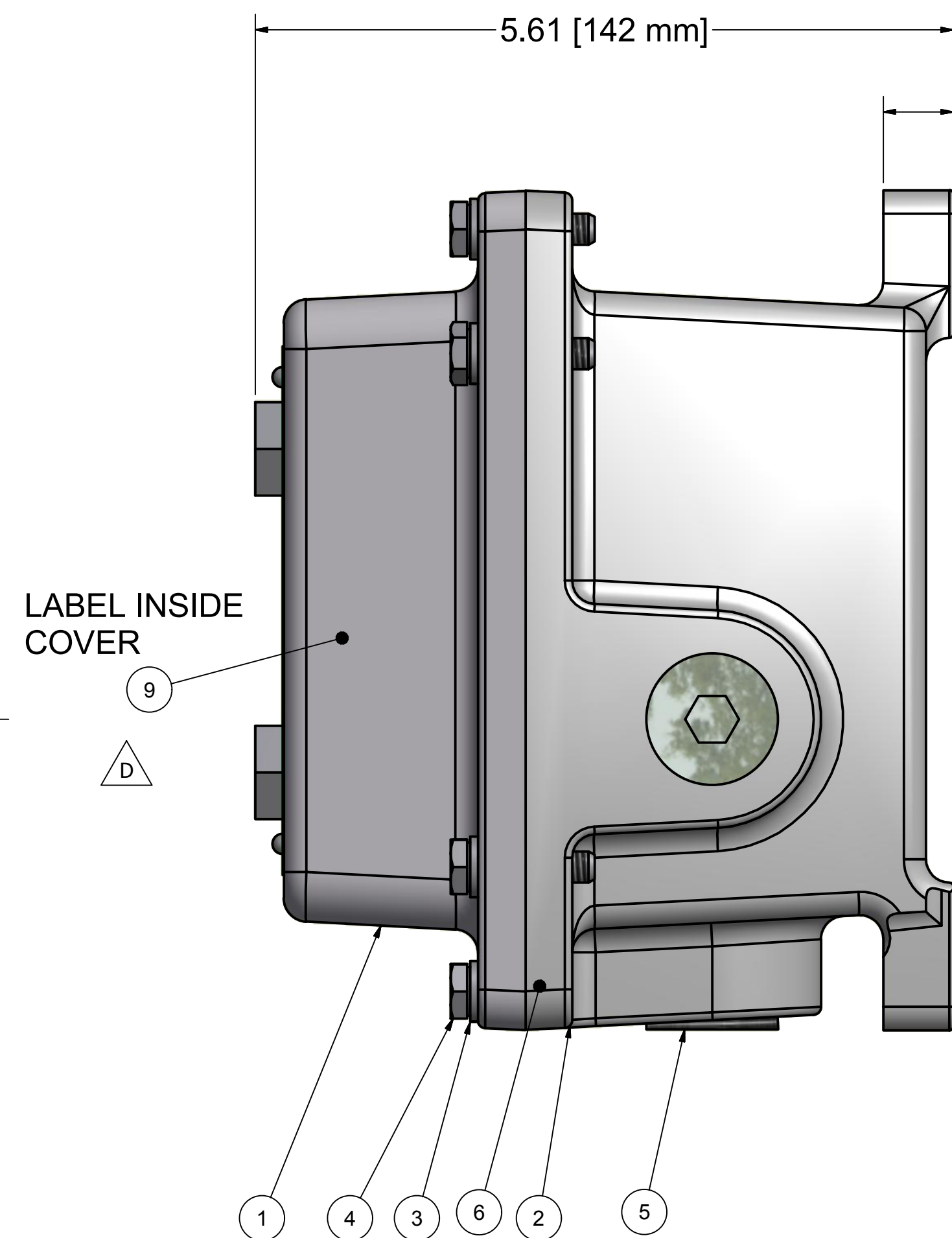
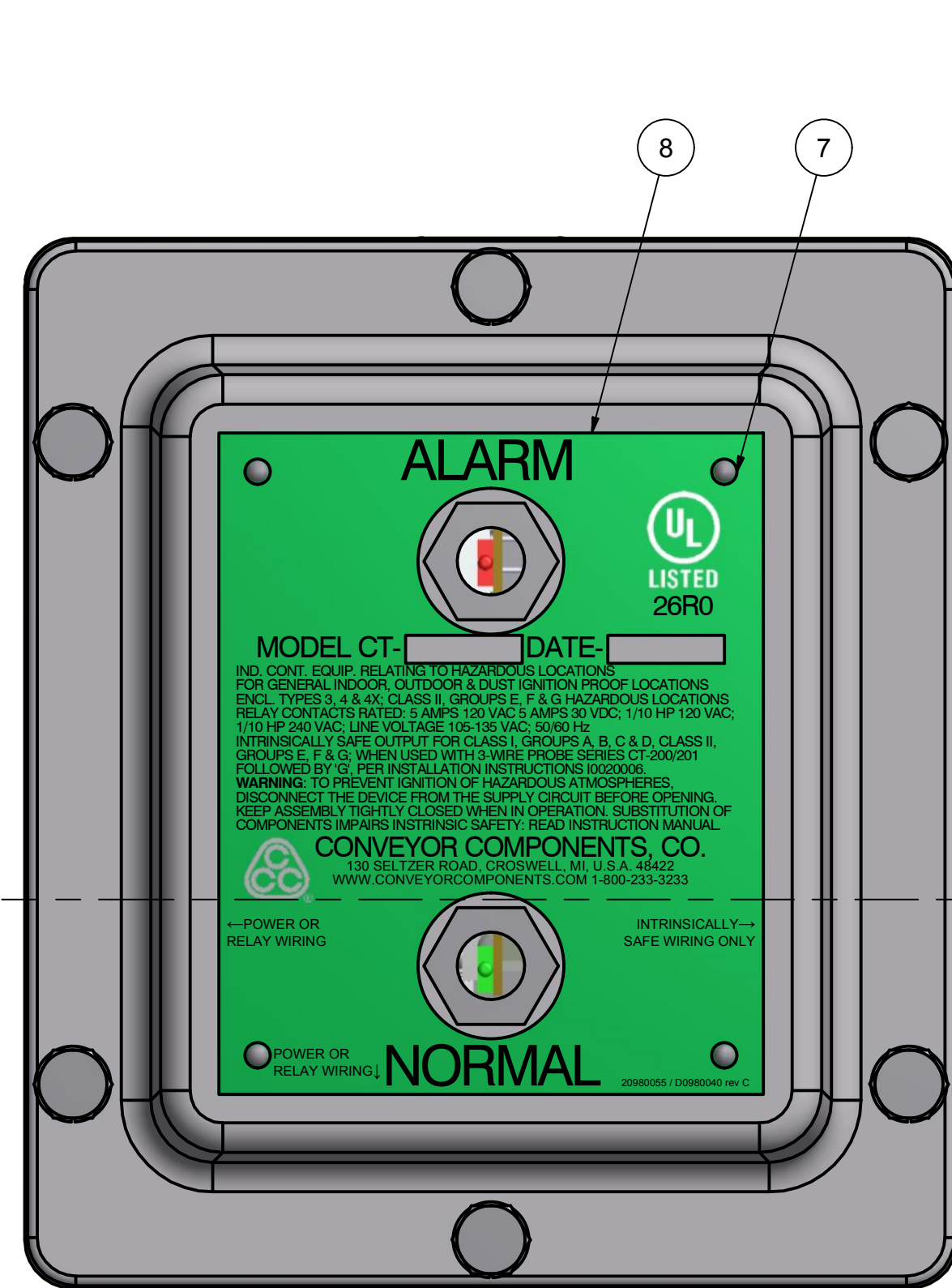

ENCLOSURE TYPE: 3, 4, 4X; CLASS II, GROUPS E, F AND G
HAZARDOUS LOCATIONS.
ALL DIMS GENERAL REFERENCE ONLY.

PARTS LIST				
ITEM	PART#	DWG	DESCRIPTION	I QTY
1	20020194	D0020038	CT COVER ASSEMBLY X-PROOF	1
2	20020192	D0020044	CT BASE ASSEMBLY DUAL RATED	1
3	22013426		1/4" SPLIT LOCKWASHER - SST	6
4	22011075		1/4-20 X 1 HEX HEAD CAP SCREW - SST; UL CTRL	6
5	CT-29		3/4" CONDUIT PLUG X-P UL RC CCN EBNV	3
6	20171079		O-RING FOR DUAL RATED RS 2-164 (PARKER N497-70); UL	1
7	22016101		#2 X 1/4 Drive Rivet - SST	4
8	20980055	D0980040	NAMEPLATE CT CONTROL- DUAL RATED, UL	1
9	20980079	D0980059	LABEL: CT CONDUCTORS / TORQUE	1

DRAWN GL	12/10/2009	Conveyor Components Company Division of Material Control, Inc. 130 Seltzer Road, Crosswell, Michigan 48422 U.S.A.
CHECKED JK	10/2/2012	
APPROVED JK	1/14/2010	TITLE
PART CT-106		CT-106 CONTROL DUAL RATED
THIS PRINT IS PROPERTY OF CONVEYOR COMPONENTS CO., AND MAY NOT BE USED IN WHOLE OR PART WITHOUT WRITTEN PERMISSION.		Drawing is computer generated, and print might not be to scale SIZE: D DWG NO: D0020029.dwg SCALE:
		REV: D SHEET 1 OF 1